

# DT4.10—4.40 Series

## 100% OIL-LESS COMPRESSORS

The Becker DT4.10—4.40 Series compressors are 100% oil-less rotary vane compressors. They are designed to operate on a continuous basis at any point from atmospheric pressure to a pressure of 15 PSIG.

The DT series compressors are direct drive units and are supplied with a TEFC flange mounted electric motor. Each pump is equipped with an integral pressure relief valve, a 10 $\mu$  inlet filter, and vibration isolators as standard equipment.

Becker DT series compressors have a reputation for being exceptionally quiet. These



newly redesigned pumps are even quieter, and operate cooler than previous units. If you are an OEM, their attractive styling will never cause embarrassment when included with your product.

These 100% oil-less, or dry, non-polluting compressors are ideal for applications where oil or water is objectionable. All Becker DT series compressors use long-life, self-lubricating graphite composite vanes. Vacuum, and combination pressure/vacuum models are also available.

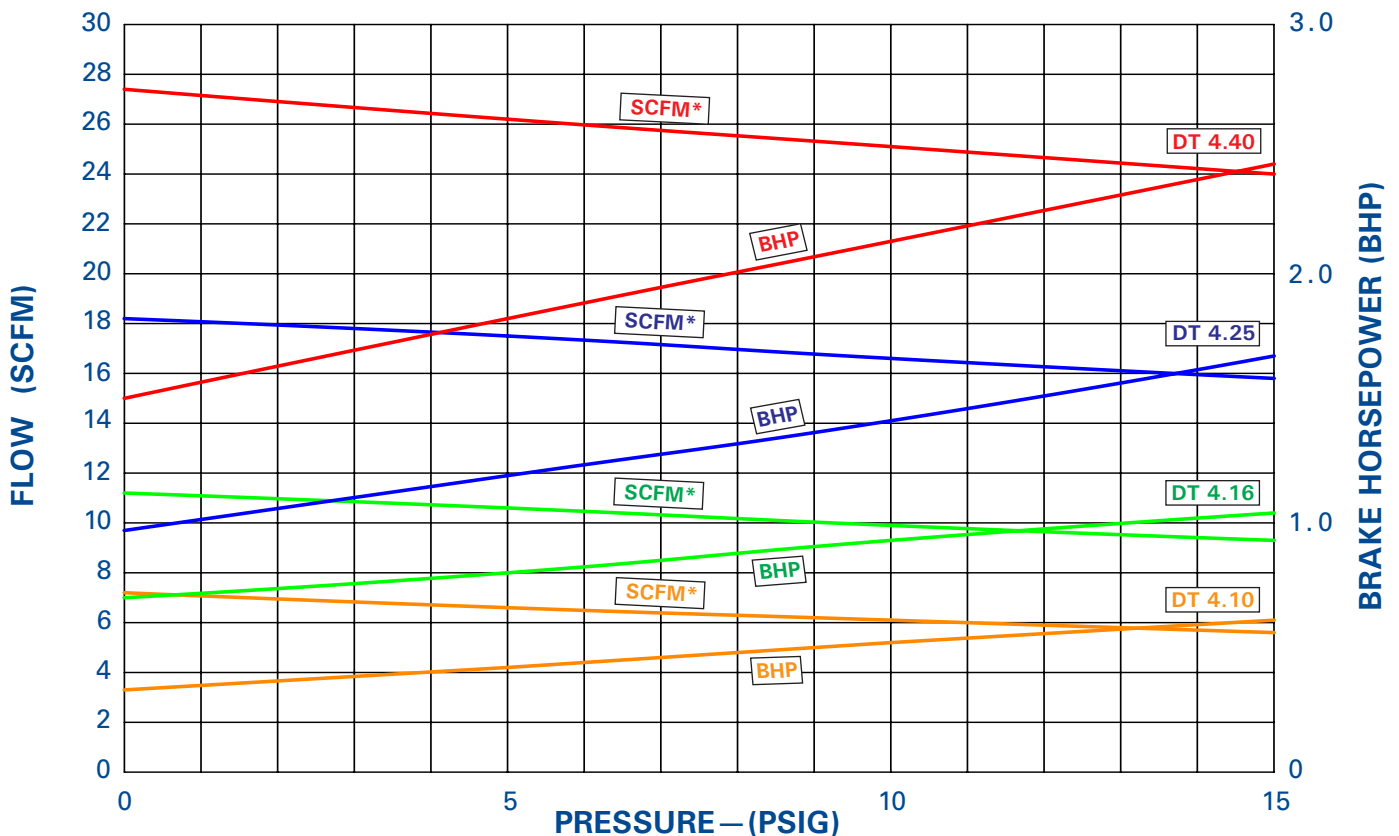

\* @ 29.92" Hg Bar. Pr.; 68°F; 36% R.H.; 0.075#/ft<sup>3</sup>

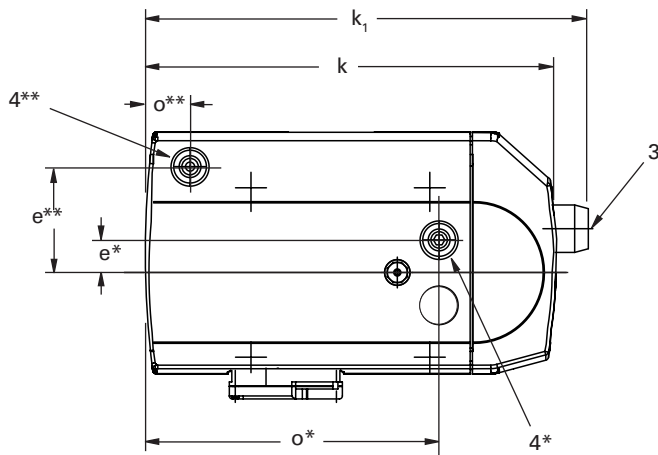
**TECHNICAL DATA**

Top View

\* :  
Models DT4.10  
& DT4.16

\*\* :  
Models DT4.25  
& DT4.40

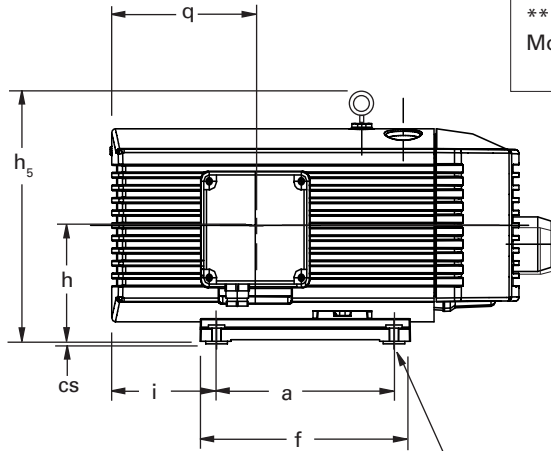

Side View

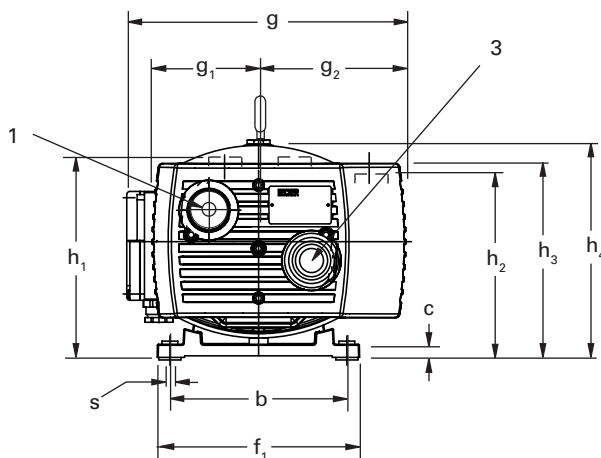

End View (Opposite Motor End)

All data based on 60 Hz operation

	DT 4.10	DT 4.16	DT 4.25	DT 4.40
Flow (SCFM @ 0 PSIG)	7.2	11.2	18.2	27.4
Horsepower	0.6	0.94	1.75	2.9
Speed (RPM)	1740	1740	1740	1740
Max. Oper. Pressure (PSIG)	15	15	15	15
Weight (lbs.)—w/ motor	35.2	51.7	80.3	101
Noise Level (Max. dBA)	½	½	¾	¾
Outlet size (BSP, inches)	(Inches)			
<b>Dimensional Data</b>	6.3	7.95	8.66	8.66
a	4.41	4.92	7.48	8.19
b	0.6	0.6	0.6	0.6
c	0.12	0.12	0.12	0.12
cs	1.38	1.38	5.12	5.12
e	7.88	9.53	10.24	10.24
f	5.6	6.1	9.37	9.37
f <sub>1</sub>	8.11	9.1	12.92	12.92
g	3.54	4.03	4.92	4.92
g <sub>1</sub>	3.54	4.03	6.81	6.81
g <sub>2</sub>	4.21	4.45	5.51	5.51
h	6.66	7.4	—	—
h <sub>1</sub>	—	—	8.43	8.43
h <sub>2</sub>	6.93	7.32	8.9	8.9
h <sub>3</sub>	7.44	8.07	9.84	9.84
h <sub>4</sub>	7.68	8.3	11.42	11.42
h <sub>5</sub>	4.17	2.88	4.45	7.0
i	15.25	16.38	19.89	23.04
k	16.9	17.8	21.46	24.61
k <sub>1</sub>	10.12	11.48	2.16	2.16
o	4.84	5.97	6.81	7.56
q	0.27	0.27	0.27	0.27
s				

Manufacturer reserves right to alter data without notice.

- 1 - Inlet
- 2 - Vibration Isolator
- 3 - Pressure Regulating Valve
- 4 - Discharge Port