

T4.16DS T4.25DSK T4.40DSK

100% OIL-LESS COMBINED PRESSURE / VACUUM PUMPS

Becker proudly introduces the T4...DS and DSK Series of 100% oil-less combination pressure and vacuum pumps. These models are primarily designed for the graphic arts applications.

This series of pumps is standard equipment on many OEM products, and is ideal for replacement of virtually any other brand—even many oil lubricated pumps. All models are totally oil-less, so there is never a chance of oil in the blast air to contaminate your product.

Newly redesigned, these pumps are built to have long life in the toughest applications on the most modern prepress, pressroom, and bindery equipment. Not only did we improve their ruggedness, but their efficiency as well. They run cooler and quieter than their predecessors.

It never hurts to have an attractive looking pump, and these pumps set new standards for aesthetics.



In fact, these pumps have been chosen by a museum for display as an example of outstanding modern industrial styling—styling that is functional as well as appealing.

T4 pumps provide plenty of blast air and suction, and are equipped with both blast and vacuum regulating valves built-in. These pumps have an improved cooling system to minimize the chance of blocking with dust and powder. T4...DSK models include a built-in aftercooler to guarantee cooler discharge air, thereby minimizing static electricity in the discharge air.

Large inlet filters are built-in, thus ensuring clean inlet air that results in longer pump life. Discharge filters are also built-in, which remove all carbon dust from the blast air.

T4 pumps are designed with service in mind. All service is accomplished from the end of the pump, in just a few minutes using standard tools.

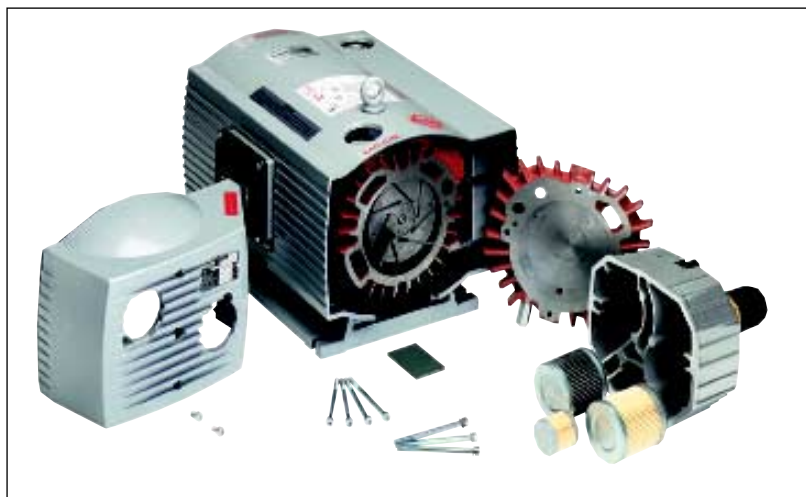

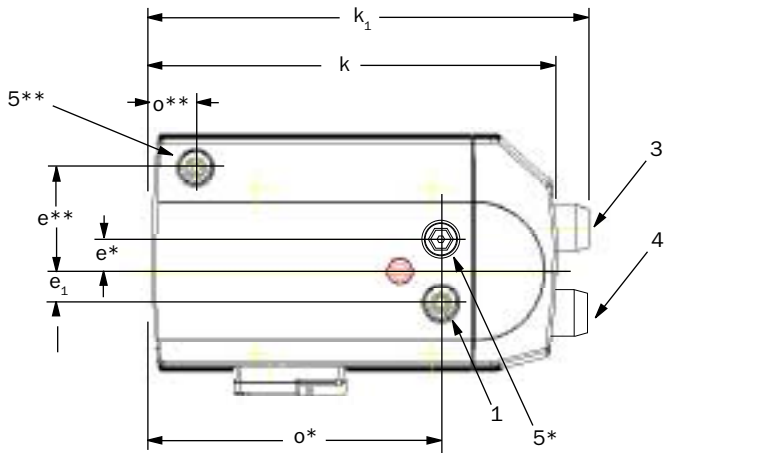
TECHNICAL DATA

Top View

* :
Models T4.16DS

** :
Models T4.25DSK
& T4.40DSK

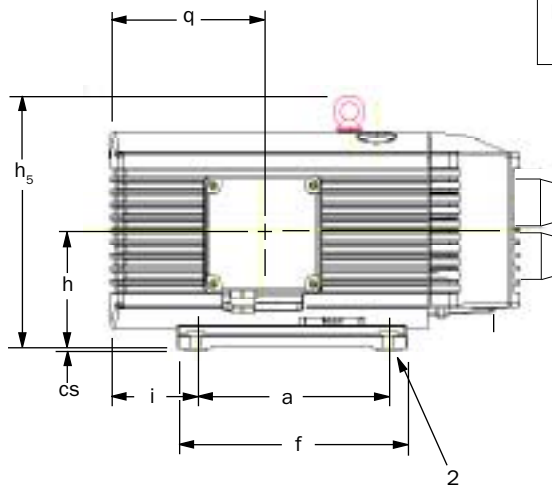

Side View

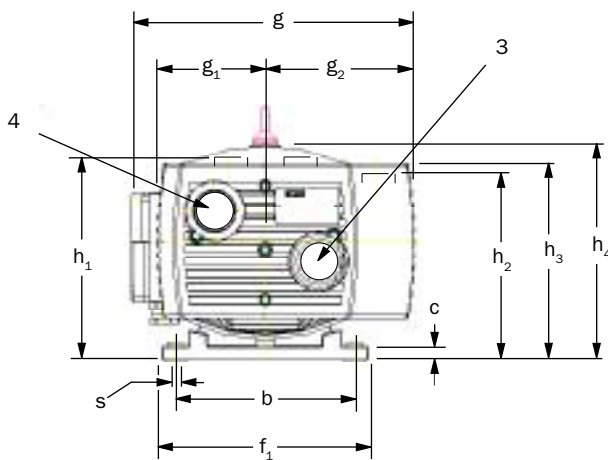

End View (Opposite Motor End)

All data based on 60 Hz operation

	T 4.16 DS	T 4.25 DSK	T 4.40 DSK
Flow (SCFM @ 0 PSIG)	11	18	28
Horsepower	0.9	1.7	2.7
Speed (RPM)	1740	1740	1740
Max. Disch. Temp. (°F) (68°F amb., 9 PSIG, 18 in.Hg)		112	108
Weight (lbs.)-w/ motor	53	77	99
Noise Level (Max. dBA)	68	72	74
Inlet/Outlet size (BSP, inches)	1/2	3/4	3/4
Dimensional Data	(Inches)		
a	7.95	8.66	8.66
b	4.92	7.48	8.19
c	0.6	0.6	0.6
cs	0.12	0.12	0.12
e	1.5	5.12	5.12
e ₁	1.5	1.57	1.57
f	9.53	10.24	10.24
f ₁	6.1	9.37	9.37
g	9.1	12.92	12.92
g ₁	4.03	4.92	4.92
g ₂	4.03	6.81	6.81
h	4.45	5.51	5.51
h ₁	7.4	8.9	8.9
h ₂	-	8.43	8.43
h ₃	7.32	8.9	8.9
h ₄	8.07	9.84	9.84
h ₅	8.3	11.42	11.42
i	2.88	4.45	7.0
k	16.38	19.89	23.04
k ₁	17.8	21.46	24.61
o	11.48	2.16	2.16
q	5.97	6.81	7.56
s	0.27	0.27	0.27

Overall dimensions of single phase units may vary. Contact factory for information
 Manufacturer reserves right to alter data without notice.

- 1 - Inlet Port
- 2 - Vibration Isolator
- 3 - Pressure Regulating Valve
- 4 - Vacuum Regulating Valve
- 5 - Discharge Port