

### DuraVane

Lubricated rotary vane pump  
RVL110H

**DuraVane** lubricated rotary vane pumps are single-stage pumps with an integrated closed loop oil recirculation system.

- Heavy duty construction.
- Compact design, small footprint.
- High-tech vane material provides long vane life.
- Gas ballast valve is standard.
- Low noise level.
- Low maintenance.
- Air-cooled design.
- Internally mounted inlet check valve.
- Float type oil-recovery valve ensures maximum air/oil separation.
- High efficiency multi-stage exhaust filter removes 99.9% of exhaust smoke.
- Direct drive.
- Simple to install.



Performance characteristics	
Displacement:	106CFM
Final pressure:	0.4Torr
Motor:	5HP/60HzTEFC
Voltage:	230V/1phase 208/230/460V/3phase
Speed:	1800RPM
Noise level(at 3ft):	72dBA
Oil reservoir cap.:	2.8qt
Oil type:	Duratex 100
Weight:	176Lbs
Inlet conn.:	1-1/2"NPT
Discharge conn.:	1-1/2"NPT

RVL110H

Based on 29.92 inch Hg barometric pressure.  
Inlet temperature 70° deg. F.

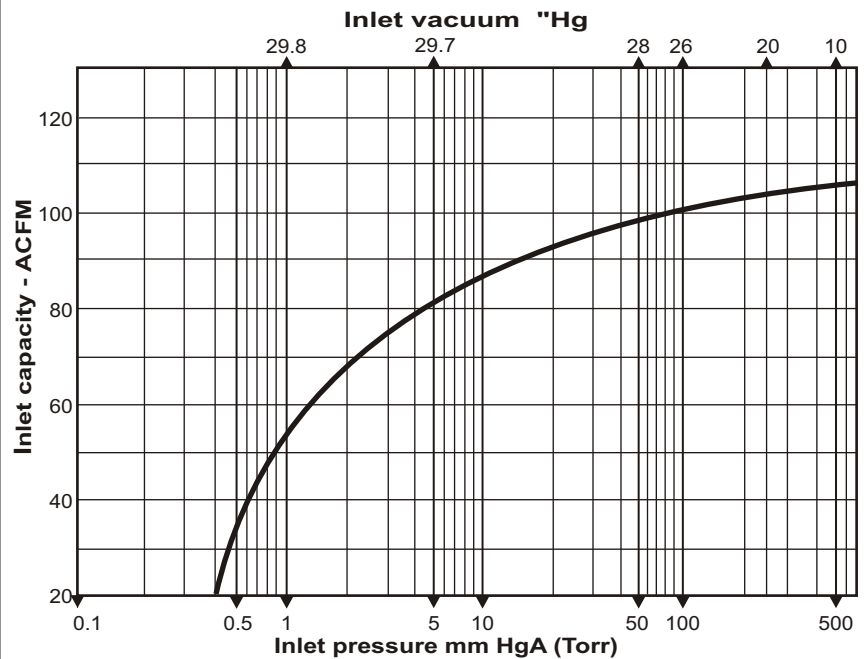

RVL110H

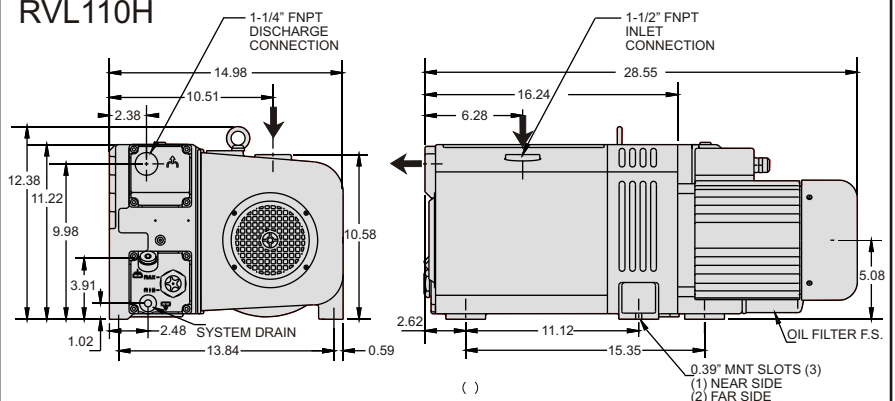

Information contained in this document is for reference only. Subject to change without notice.