

**DuraVane** lubricated rotary vane pumps for saturated air (wet) service are specifically developed for applications with a high level of inlet water vapor. Standard lubricated pumps would not operate successfully under these conditions.

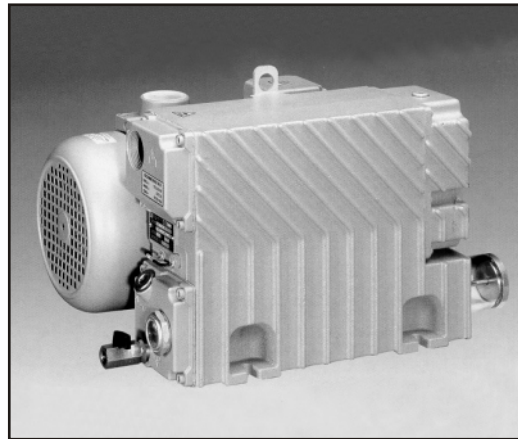

**Performance characteristics**

Displacement:	28CFM
Final pressure:	1.5Torr
Motor:	2HP/60HzTEFC
Voltage:	208/230/460V/3phase
Speed:	1800RPM
Noise level(at 3ft):	67dBA
Oil reservoir cap.:	1.6qt
Oil type:	Duratex 68
Weight:	112Lbs
Inlet conn.:	1"NPT
Discharge conn.:	1-1/4"NPT

*Suitable for continuous operation in a pressure range from 450-1.5 Torr.*

- Heavy duty construction.
- Oil/water separator with condensate drain valve.
- High oil level switch.
- Compact design, small footprint.
- High-tech vane material provides long vane life.
- Air-cooled design.
- Internally mounted inlet check valve.
- High efficiency multi-stage exhaust filter removes 99.9% of exhaust smoke.
- Direct drive.
- Simple to install.

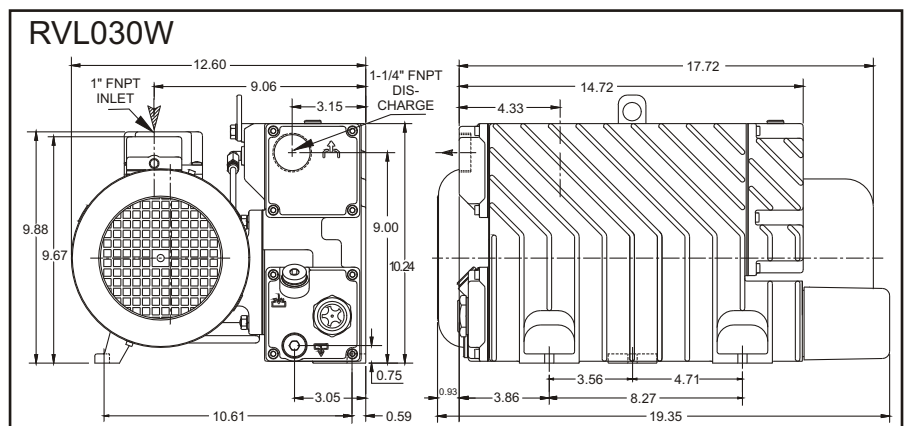
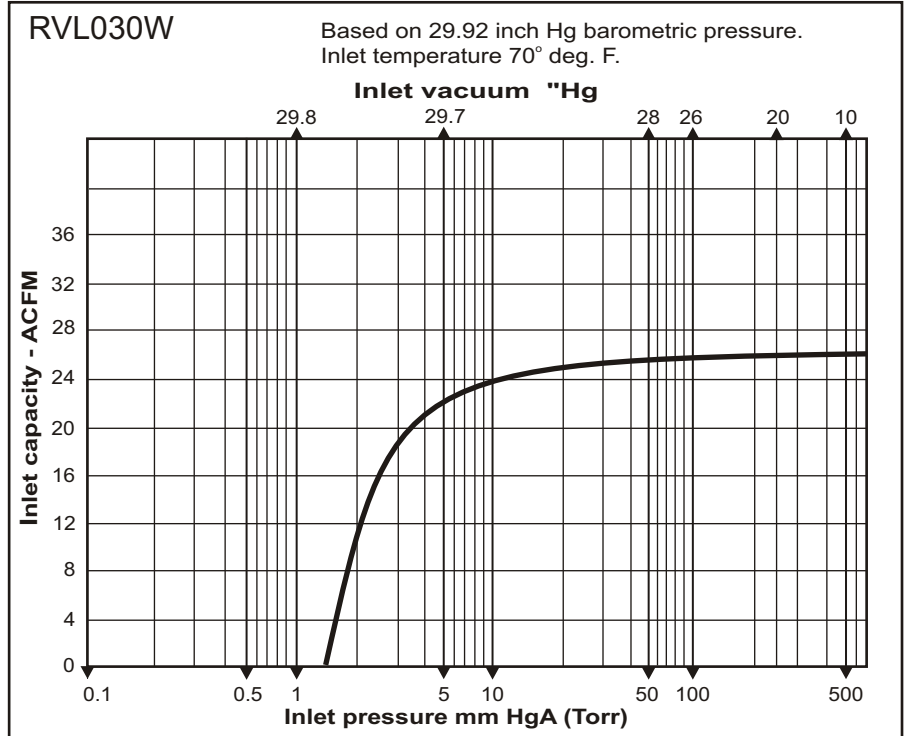

Information contained in this document is for reference only. Subject to change without notice.