

DuraVane

Lubricated rotary vane pump
for saturated air (wet) service
RVL020W

DuraVane lubricated rotary vane pumps for saturated air (wet) service are specifically developed for applications with a high level of inlet water vapor. Standard lubricated pumps would not operate successfully under these conditions.

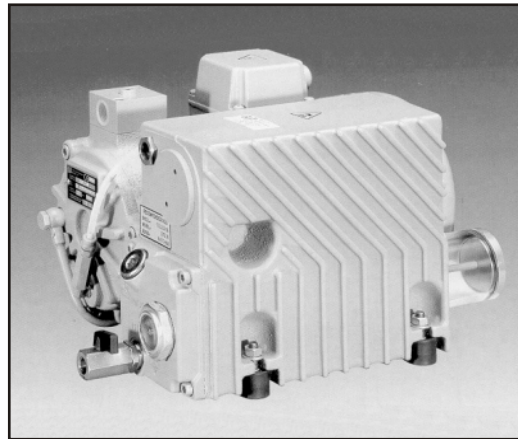

Performance characteristics

Displacement:	19CFM
Final pressure:	1.5Torr
Motor:	1.25HP/60HzTEFC
Voltage:	208/230/460V/3phase
Speed:	1800RPM
Noise level(at 3ft):	65dBA
Oil reservoir cap.:	1qt
Oil type:	Duratex 68
Weight:	56Lbs
Inlet conn.:	1/2"NPT
Discharge conn.:	1/2"NPT

Suitable for continuous operation in a pressure range from 450-1.5 Torr.

- Heavy duty construction.
- Oil/water separator with condensate drain valve.
- High oil level switch.
- Compact design, small footprint.
- High-tech vane material provides long vane life.
- Air-cooled design.
- Internally mounted inlet check valve.
- High efficiency multi-stage exhaust filter removes 99.9% of exhaust smoke.
- Direct drive.
- Simple to install.

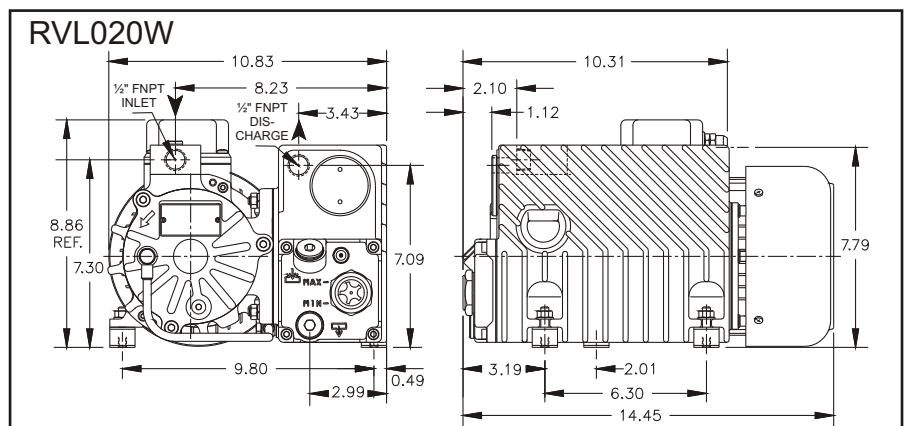
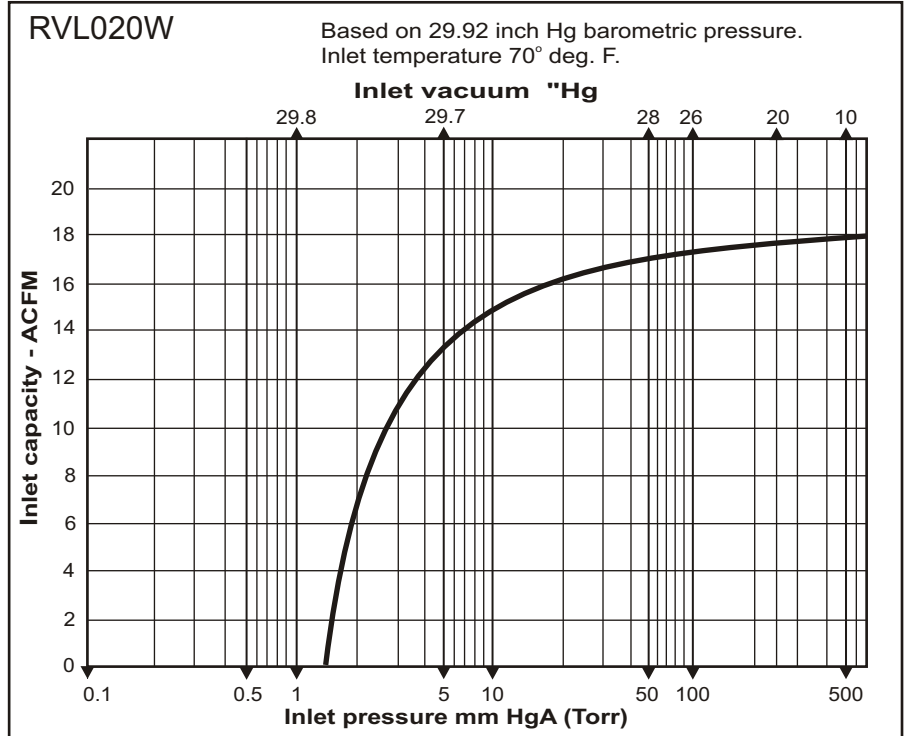

Information contained in this document is for reference only. Subject to change without notice.

Contact us at 1-800-521-2083 or email at: sales@combinedfluidproducts.com • Request Information