

DuraVane lubricated rotary vane pumps are single-stage pumps with an integrated closed loop oil recirculation system.

- Heavy duty construction.
- Compact design, small footprint.
- High-tech vane material provides long vane life.
- Gas ballast valve is standard.
- Low noise level.
- Low maintenance.
- Air-cooled design.
- High efficiency multi-stage exhaust filter removes 99.9% of exhaust smoke.
- Direct drive.
- Simple to install.

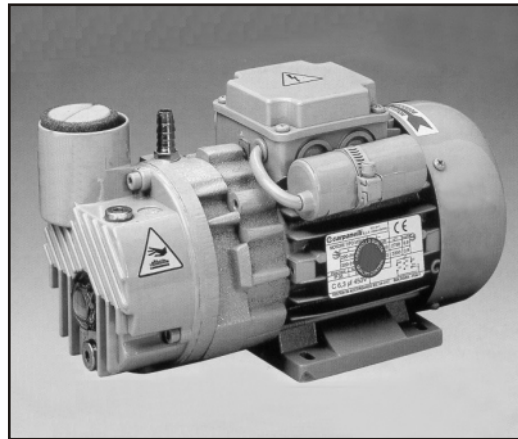

Performance characteristics

Displacement:	2.6CFM
Final pressure:	1.5Torr
Motor:	0.2HP/60HzTEFC
Voltage:	110V/1phase
Speed:	3400RPM
Noise level(at 3ft):	60dBA
Oil reservoir cap.:	0.06qt
Oil type:	Duratex 32
Weight:	12Lbs
Inlet conn.:	3/8" hose
Discharge conn.:	-

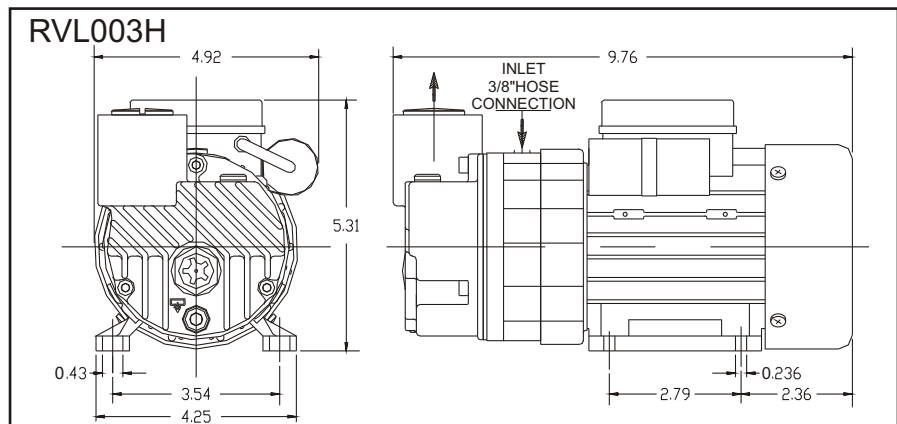
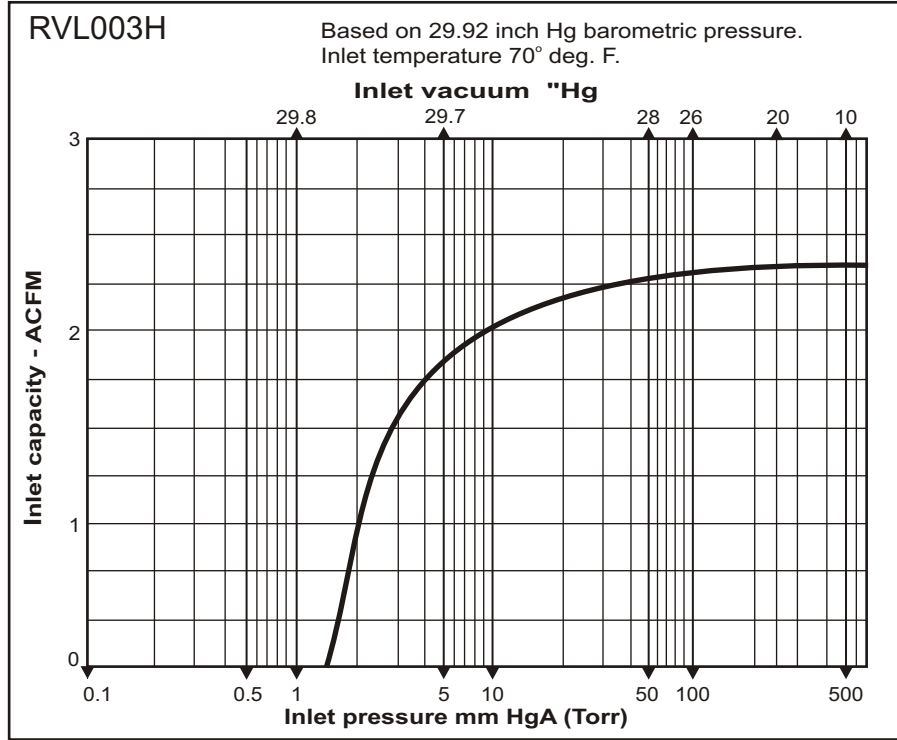

Information contained in this document is for reference only. Subject to change without notice.

Contact us at 1-800-521-2083 or email at: sales@combinedfluidproducts.com • Request Information